

Ace Roto-Mold

New Product Release

1750 Gallon Cone Bottom Tank

Den Hartog Industries is pleased to announce the addition of a new Cone Bottom tank to our portfolio of products. Cone Bottom Tanks are designed for the containment of all chemicals rated for contact with polyethylene in indoor or outdoor installations. Tank does require use of CB090-15ST stand for support.



Part No.	Capacity	Description	Weight	Tank Dimensions
CB1750-90	1,750 Gallons	Cone Bottom Tank	308	91 x 83

FEATURES:

- Tank features a bottom sump for fitting installation.
- Tank is furnished with a 16" Vented Lid Assembly and 2" FPT polypropylene fitting with Santoprene Gasket standard.
- Standard weight tank is designed for chemicals with specific gravity of 1.7 or lower.
- Tanks are manufactured from linear low density polyethylene with UV stabilizers.
- Tank walls are translucent for level view and equipped with gallon indicators.

March 2024

Ph: 800-342-3408
Fax: 712-752-8222

www.denhartogindustries.com
sales@denhartogindustries.com

 **Den Hartog**
INDUSTRIES, INC.
"Always at Your Service"



Warning: Cancer and Reproductive Harm.
www.p65Warnings.ca.gov

4010 Hospers Dr. South
Hospers, IA 51238

DEN HARTOG INDUSTRIES, INC.
 Copyright. All information furnished within this document, electronic file or design correspondence is the property of Den Hartog Industries, Inc. and shall not be used, disclosed to others or copied without the expressed written consent of Den Hartog Industries, Inc.

CB1750-90

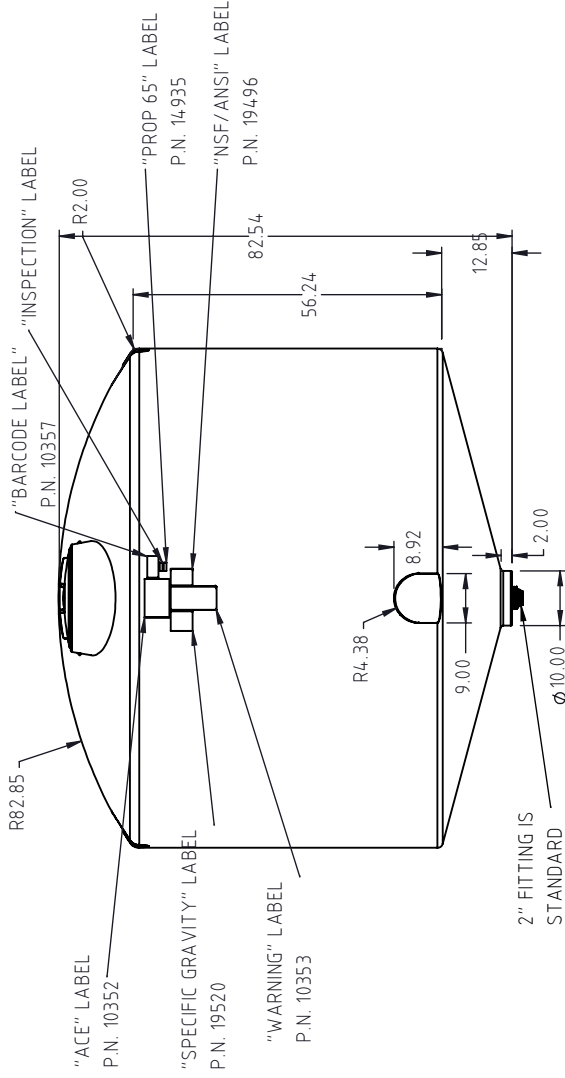
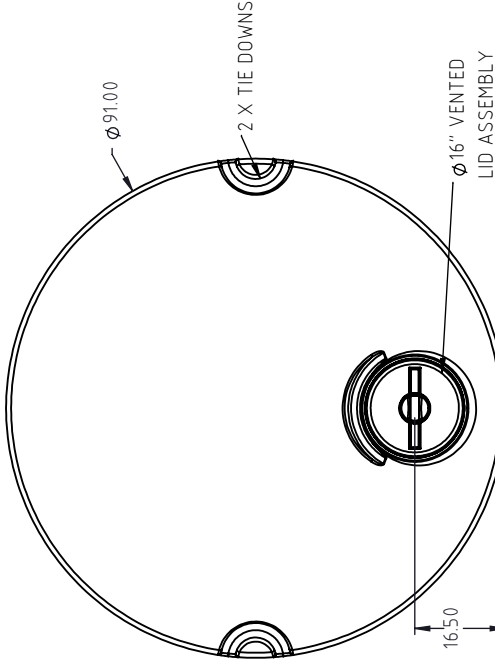

REV.	DESCRIPTION	BY	DATE	CCN
	ALL DIMENSIONS ARE IN DECIMAL INCHES TOLERANCES UNLESS OTHERWISE SPECIFIED			
	POLYETHYLENE ±1% @ 68°F			
	METAL DECIMAL ± .125" FRACTION ± 1/4" ANGLE ± 1°			
	THIRD ANGLE PROJECTION ANSI 14.5W			

DRAWN / DATE
SAS 10/3/2023

APPRD. / DATE
BES 3/18/2024

SHOT WEIGHT: 335 LBS.

SHIPPING WEIGHT: 337 LBS.

FINISH:

MATERIAL :
LLDPE

NOTES:
NOMINAL WALL THICKNESS:
0.30"



Den Hartog
INDUSTRIES, INC.

Ace Roto-Mold • Injection Molding • Blow Molding • Sowjoy
 4010 HOSPERS DRIVE S. BOX 425, HOSPERS, IOWA 51238-0425

DESCRIPTION 1750 GALLON 15 DEG. CONE BOTTOM TANK

SCALE N.S. PART NO. CB1750-90

SHEET 1 OF 1

DEN HARTOG INDUSTRIES, INC.
 Copyright. All information furnished within this document, electronic file or design correspondence is the property of Den Hartog Industries, Inc. and shall not be used, disclosed to others or copied without the expressed written consent of Den Hartog Industries, Inc.

CB1750-90+90-15ST

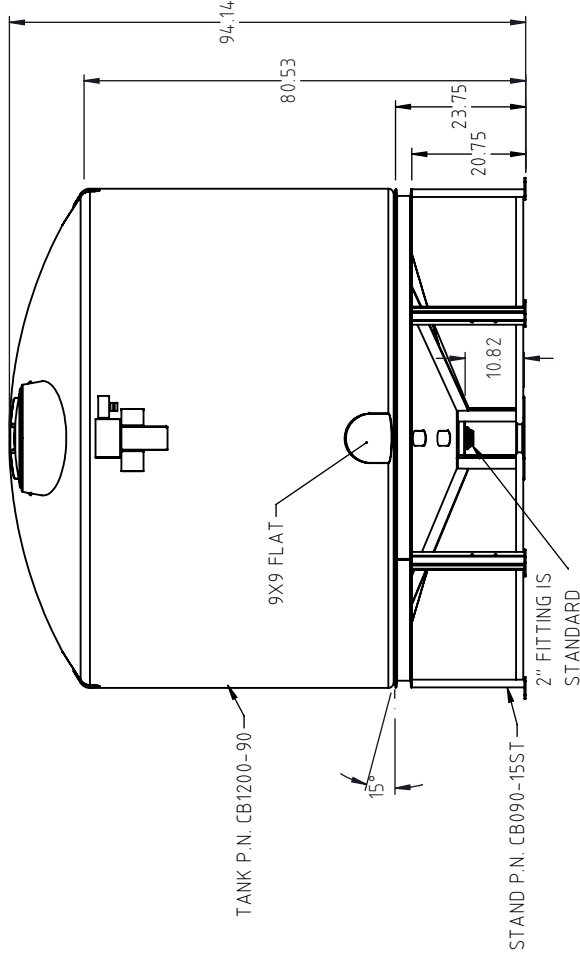
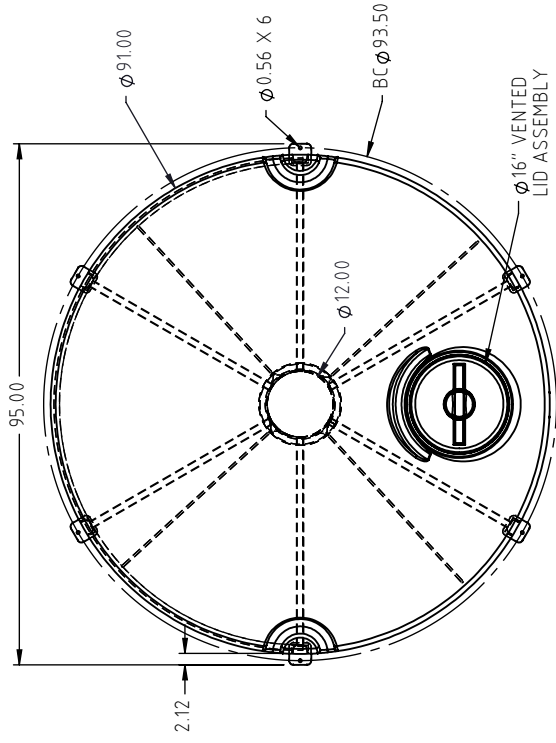

DRAWN / DATE SAS 9/19/2023		MATERIAL : SEE COMPONENTS	
APPRD. / DATE BES 3/18/2024		NOTES:	
SHOT WEIGHT:		SHIPPING WEIGHT:	
FINISH:		FINISH:	

REV.	DESCRIPTION	BY	DATE	CCN
ALL DIMENSIONS ARE IN DECIMAL INCHES TOLERANCES UNLESS OTHERWISE SPECIFIED				
POLYETHYLENE		METAL		
DECIMAL ± .125"		FRACTION ± 1/4"		
ANGLE ± 1°		THIRD ANGLE PROJECTION ANSI 14.5W		



Den Hartog INDUSTRIES, INC.
 Ace Roto-Mold • Injection Molding • Blow Molding • Sowjoy
 4010 HOSPERS DRIVE S. BOX 425, HOSPERS, IOWA 51238-0425

DESCRIPTION	1750 GALLON Ø90" 15° CONE BOTTOM TANK AND STAND
SCALE	N.S.
PART NO.	CB1750-90+90-15ST
SHEET	1 OF 1