

Copyright. All information furnished within this document, electronic file or design correspondence is the property of Den Hartog industries, Inc. and shall not be used, disclosed to others or copied without the expressed written consent of Den Hartog Industries, Inc.

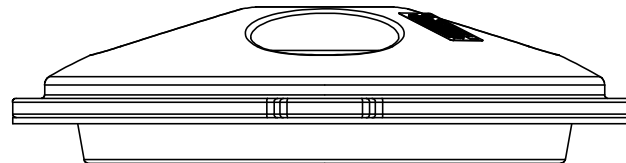

				DRAWN / DATE ADH 12/5/16	MATERIAL HDPE-3 MELT REGRIND 11017
				APPRO. / DATE REH 7/19/17	
REV	DESCRIPTION	BY / DATE	CCN	SHOT WEIGHT: 17 LBS	NOTES:
				SHIPPING WEIGHT:	
				FINISH:	
ALL DIMENSIONS ARE IN DECIMAL INCHES TOLERANCES UNLESS OTHERWISE SPECIFIED		THIRD ANGLE PROJECTION ANSI 14.5M			
POLYETHYLENE $\pm 1\%$ @ 68°F					
METAL DECIMAL $\pm .125$ " FRACTION $\pm 1/4$ " ANGLE $\pm 1^\circ$					

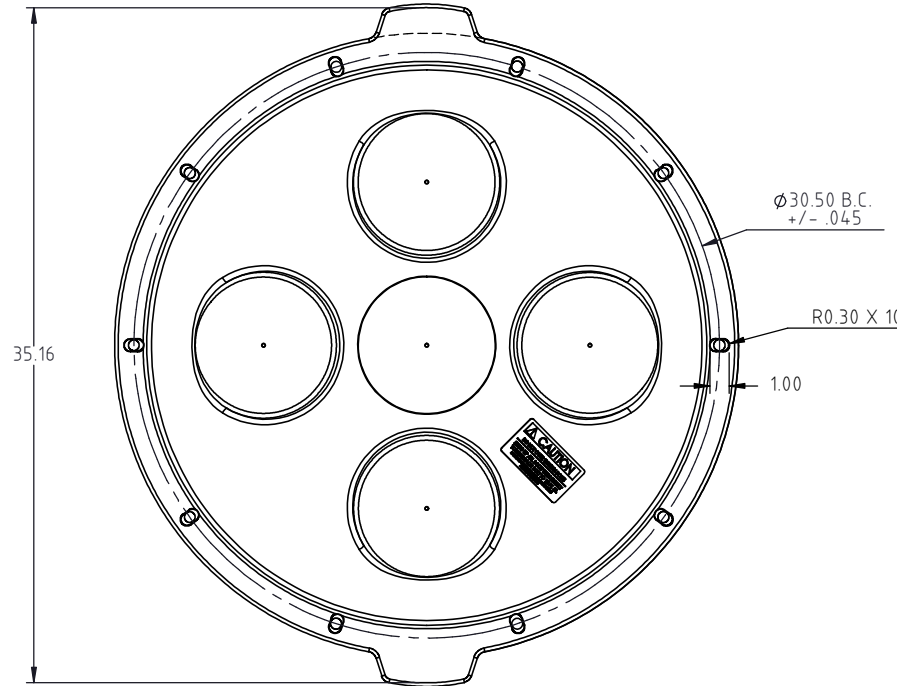
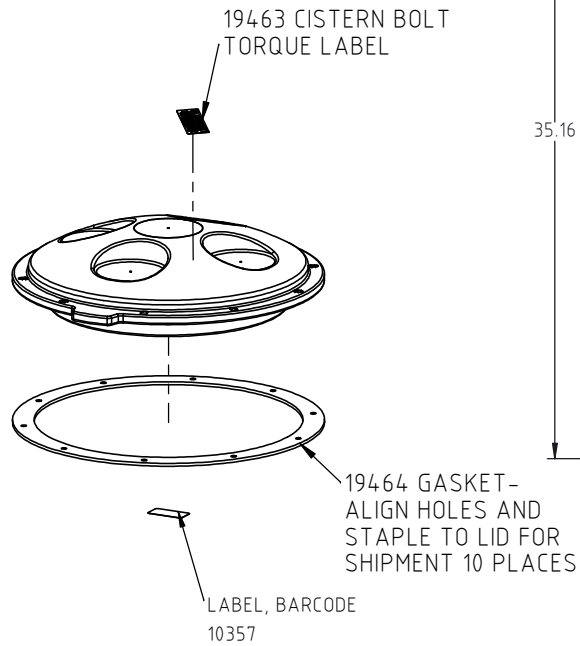

Den Hartog
INDUSTRIES, INC.

Acra Roto-Mold Injection Molding Blow Molding Sowjoy

4010 HOSPERS DRIVE S. BOX 425, HOSPERS, IOWA 51238-0425

DESCRIPTION	LOW PROFILE SEPTIC TANK BURIAL LID ASSEMBLY	
SCALE	N.S.	PART NO. ACT-16053BK