

© DEN HARTOG INDUSTRIES, INC.

Copyright. All information furnished within this document, electronic file or design correspondence is the property of Den Hartog industries, Inc. and shall not be used, disclosed to others or copied without the expressed written consent of Den Hartog Industries, Inc.

ITEM NO.	PART NUMBER	DESCRIPTION	QTY.
1	CB086-45ST-1	ANGLED SUPPORT STRAP	6
2	CB086-45ST-2	3" CHANNEL LEG	2
3	CB086-45ST-3	RIGHT LEG	1
4	CB086-45ST-4	LEFT LEG	1
5	CB086-45ST-5	3" CHANNEL RING	1
6	CB086-45ST-6	ANGLED ANGLE SUPPORT	6
7	CB086-45ST-7	ANGLED SUPPORT STRAP	6
8	CB086-45ST-8	OUTSIDE BASE RING PIPE	6
9	12750	LEG PAD, 1/4" X 4" X 4"	6
10	12476	PAN, W/HOLES	1
11	CB086-45ST-11	BASE SUPPORT PIPE	6
12	CB086-45ST-12	3" CHANNEL LEG-POWDER COAT	2
13	12521	3/16" X 2" ANGLE	1
14	12477	PAN	2

CB086-45ST

H

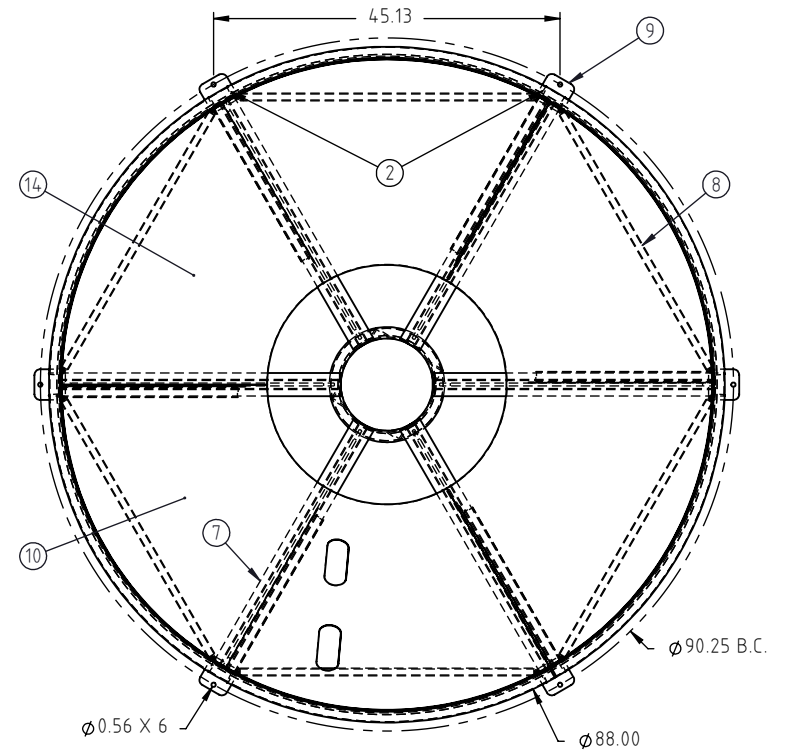
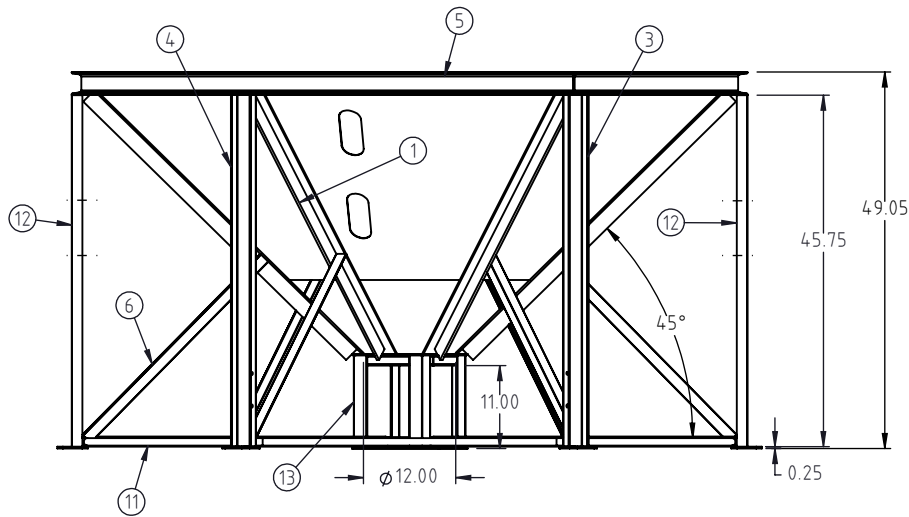

H

H	UPDATED SHEET FORMAT	SRA	7/21/2023	4447	DRAWN / DATE	MATERIAL :
G	HOLES FOR POWDER COATING ADDED TO TWO LEGS. PARTS TABLE UPDATED	ADH	7/22/2011	2254	ADH 6/27/2007	SEE COMPONENTS
F	DIMENSION AND MATERIAL P.N. CORRECTED 12750 WAS S.J.CB85/90ST .56 WAS .63 WEIGHT AND FINISH ADDED	ADH	1/28/2010	1995	APPRD. / DATE	
REV.	DESCRIPTION	BY	DATE	CCN	REH 7/18/2007	
ALL DIMENSIONS ARE IN DECIMAL INCHES TOLERANCES UNLESS OTHERWISE SPECIFIED		THIRD ANGLE PROJECTION ANSI 14.5M		SHOT WEIGHT:		NOTES:
POLYETHYLENE		METAL		SHIPPING WEIGHT: 580.00 LBS		
±1% @ 68°F		DECIMAL ± .125" FRACTION ± 1/4" ANGLE ± 1°		FINISH: Powder Coat		



Den Hartog
INDUSTRIES, INC.

Ace Roto-Mold • Injection Molding • Blow Molding • Sowjoy
4010 HOSPERS DRIVE S. BOX 425, HOSPERS, IOWA 51238-0425

DESCRIPTION		CB, STAND 86" DIA 45 DEG	
SCALE	N.S.	PART NO.	CB086-45ST
SHEET		1 OF 1	