

Copyright. All information furnished within this document, electronic file or design correspondence is the property of Den Hartog industries, Inc. and shall not be used, disclosed to others or copied without the expressed written consent of Den Hartog Industries, Inc.

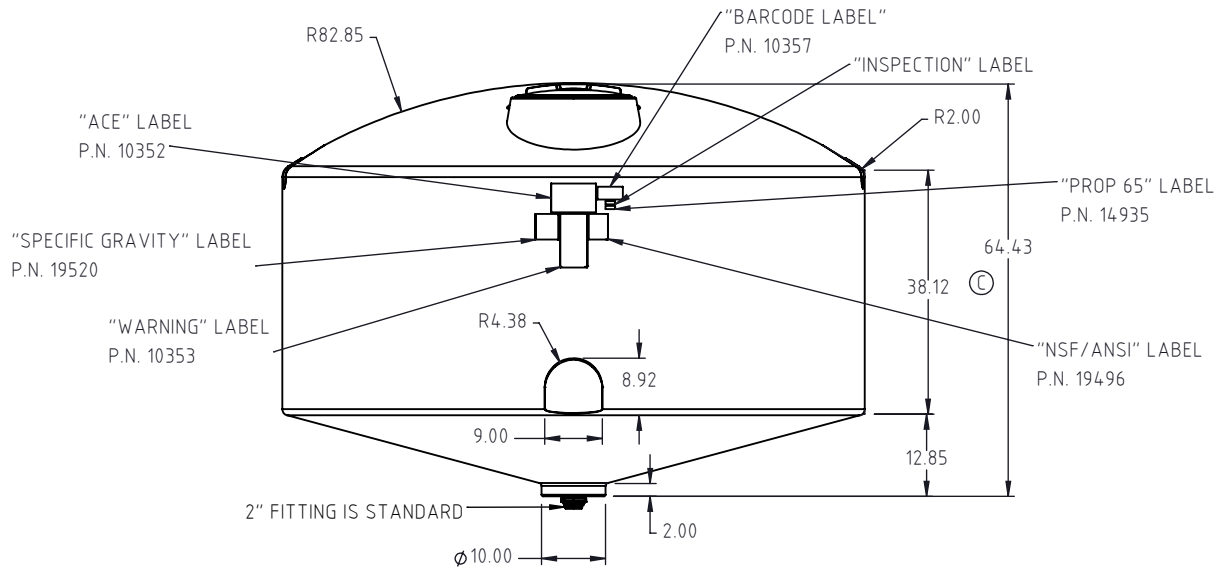

2" FITTING IS STANDARD

C	UPDATED TEMPLATE, 38.12 WAS 38, 64.43 WAS 62.	SRA	4/17/2024	4590	DRAWN / DATE	MATERIAL :
B	WAS 90	DHJ	5/11/17	3385	DHJ 3/2/1995	LLDPE
A	ISOLATED TANK FROM STAND	NVE	5/23/2006	----	APPRD. / DATE	
REV.	DESCRIPTION	BY	DATE	CCN	REH 4/18/2007	
ALL DIMENSIONS ARE IN DECIMAL INCHES TOLERANCES UNLESS OTHERWISE SPECIFIED		THIRD ANGLE PROJECTION ANSI 14.5M		SHOT WEIGHT: 240.00 LBS.	NOTES:	
POLYETHYLENE		METAL		SHIPPING WEIGHT: 242.00 LBS.	NOMINAL WALL THICKNESS: 0.28"	
±1% @ 68°F				FINISH:		

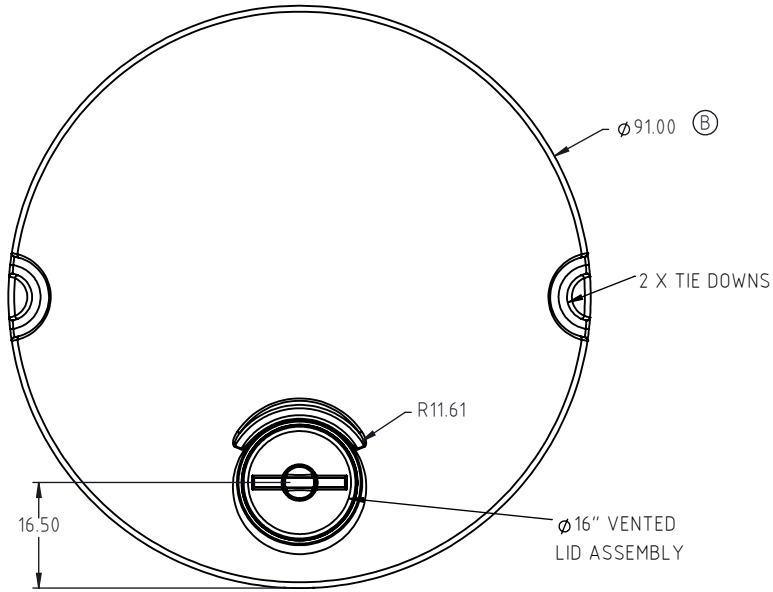
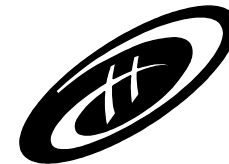

**Den Hartog  
INDUSTRIES, INC.**

Ace Roto-Mold • Injection Molding • Blow Molding • Sowjoy  
4010 HOSPERS DRIVE S. BOX 425, HOSPERS, IOWA 51238-0425

DESCRIPTION 1200 GALLON 90" DIA 15 DEG CONE BOTTOM TANK		
SCALE N.S.	PART NO. CB1200-90	SHEET 1 OF 1

Copyright. All information furnished within this document, electronic file or design correspondence is the property of Den Hartog industries, Inc. and shall not be used, disclosed to others or copied without the expressed written consent of Den Hartog Industries, Inc.

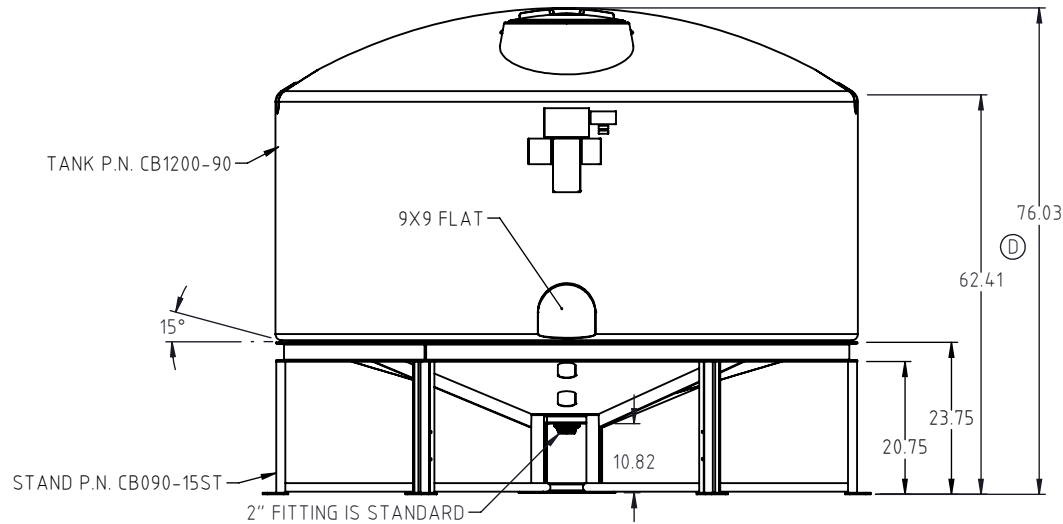
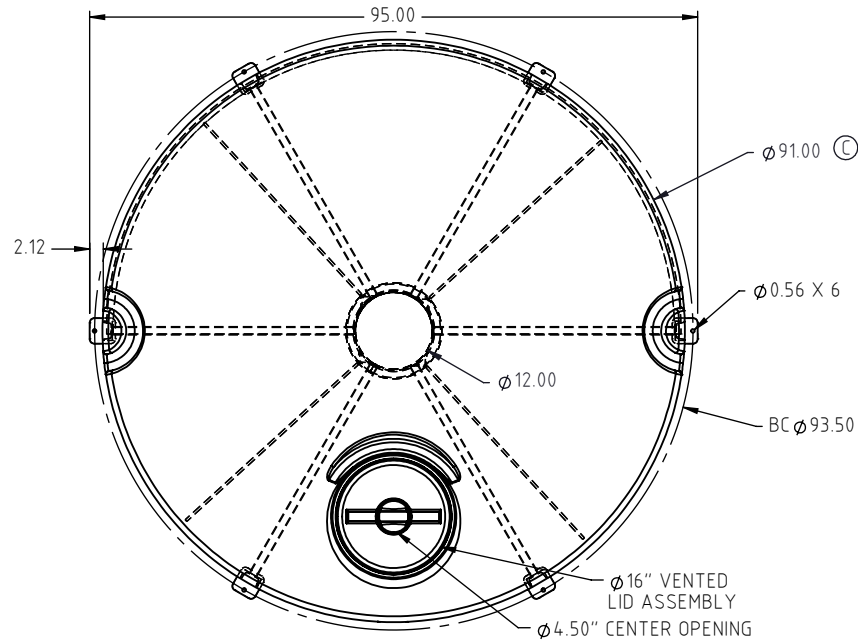

D	CB1200-90 TANK SIZING UPDATED	SRA	4/17/2024	4590	DRAWN / DATE	MATERIAL :
C	WAS 90	DHJ	5/11/2017	3385	DHJ 3/2/1995	SEE COMPONENTS
B	REMOVE TOL. 1% @68°F	GWC	3/9/07	----	APPRD. / DATE	
REV.	DESCRIPTION	BY	DATE	CCN	REH 4/18/2007	
ALL DIMENSIONS ARE IN DECIMAL INCHES TOLERANCES UNLESS OTHERWISE SPECIFIED				THIRD ANGLE PROJECTION ANSI 14.5M	SHOT WEIGHT:	NOTES:
POLYETHYLENE		METAL			SHIPPING WEIGHT:	1. TANK WEIGHT: 242 LBS.
DECIMAL ± .125"		FRACTION ± 1/4"			FINISH:	2. STAND WEIGHT: 380 LBS.
ANGLE ± 1°						



**Den Hartog  
INDUSTRIES, INC.**

Ace Roto-Mold • Injection Molding • Blow Molding • Sowjoy  
4010 HOSPERS DRIVE S. BOX 425, HOSPERS, IOWA 51238-0425

DESCRIPTION		
1200 GALLON Ø90" 15° CONE BOTTOM TANK AND STAND		
SCALE	PART NO.	SHEET.
N.S.	CB1200-90+90-15ST	1 OF 1