

Copyright. All information furnished within this document, electronic file or design correspondence is the property of Den Hartog industries, Inc. and shall not be used, disclosed to others or copied without the expressed written consent of Den Hartog Industries, Inc.

ITEM NO.	PART NUMBER	DESCRIPTION	QTY.
1	CB122-15ST-1	PAN SUPPORT STRAP	8
2	CB122-15ST-2	CHANNEL RING	1
3	CB122-15ST-3	STAND LEG	6
4	CB122-15ST-9	ANGLE SUPPORT	8
5	CB122-15ST-10	BASE PIPE	8
6	CB122-15ST-11	LEG BRACE	8
7	CB122-15ST-12	TOP BRACE	8
8	CB122-15ST-13	STAND LEG-POWDER COAT	2
9	12467	LEG PAD, 3/8" X 6" X 6"	8
10	12474	PAN WITH HOLES	1
11	12475	PAN	2
12	12518	Ø14" CENTER STAND	1

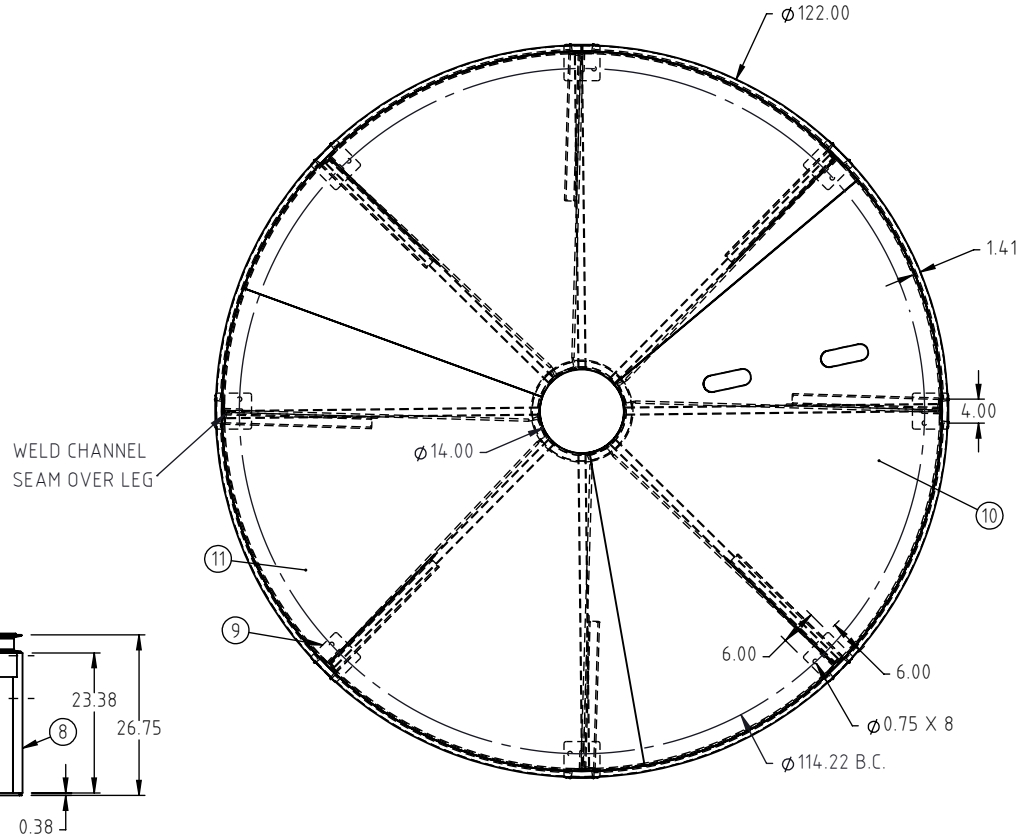
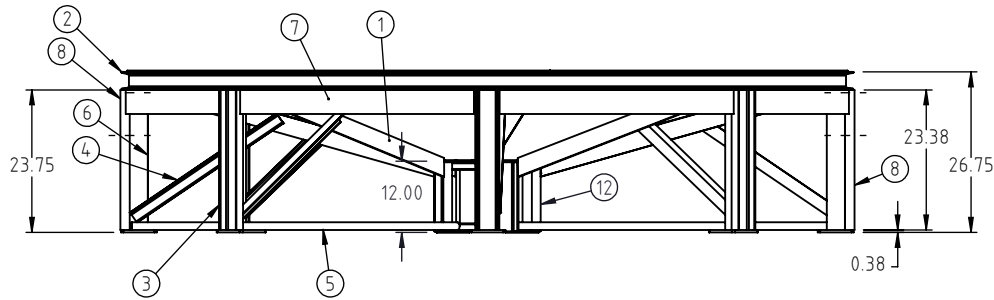

Ⓜ

H	UPDATED TEMPLATE & DESCRIPTION	BES	7/25/2023	4447	DRAWN / DATE	MATERIAL :
G	CLOCKING OF CB122-15-1 SHOWN ON PRINT & DIMENSION CORRECTED.	ADH	10/26/16	3312	ADH 7/6/2007	SEE COMPONENTS
F	HOLES FOR POWDER COATING ADDED TO TWO LEGS COMPONENT TABLE UPDATED, WEIGHT, FINISH ADDED	ADH	7/22/11	2254	APPRD. / DATE	
REV.	DESCRIPTION	BY	DATE	CCN	REH 7/18/2007	
ALL DIMENSIONS ARE IN DECIMAL INCHES TOLERANCES UNLESS OTHERWISE SPECIFIED		THIRD ANGLE PROJECTION ANSI 14.5M		SHOT WEIGHT:		NOTES:
POLYETHYLENE		METAL		SHIPPING WEIGHT: 1020.00 LBS		
±1% @ 68°F		DECIMAL ± .125" FRACTION ± 1/4" ANGLE ± 1°		FINISH: Powder Coat		



**Den Hartog**  
**INDUSTRIES, INC.**

Ace Roto-Mold • Injection Molding • Blow Molding • Sowjoy  
4010 HOSPERS DRIVE S. BOX 425, HOSPERS, IOWA 51238-0425

DESCRIPTION		CB, STAND 122" DIA 15 DEG	
SCALE	N.S.	PART NO.	CB122-15ST
			SHEET 1 OF 1