

© DEN HARTOG INDUSTRIES, INC.

Copyright. All information furnished within this document, electronic file or design correspondence is the property of Den Hartog industries, Inc. and shall not be used, disclosed to others or copied without the expressed written consent of Den Hartog Industries, Inc.

FS0510-HPS

E

FS0510-HP 3 PER SET

DETAIL A
SCALE 1:2

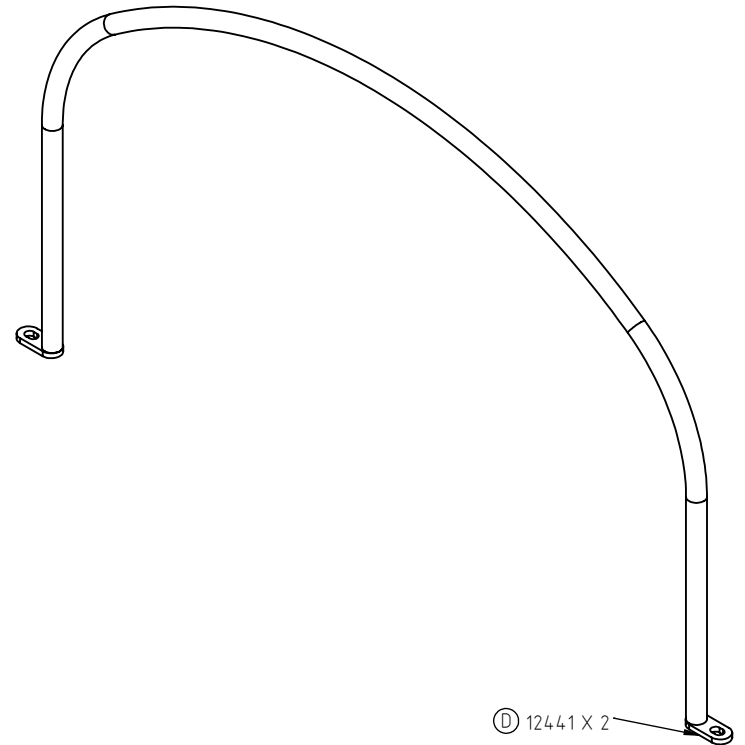
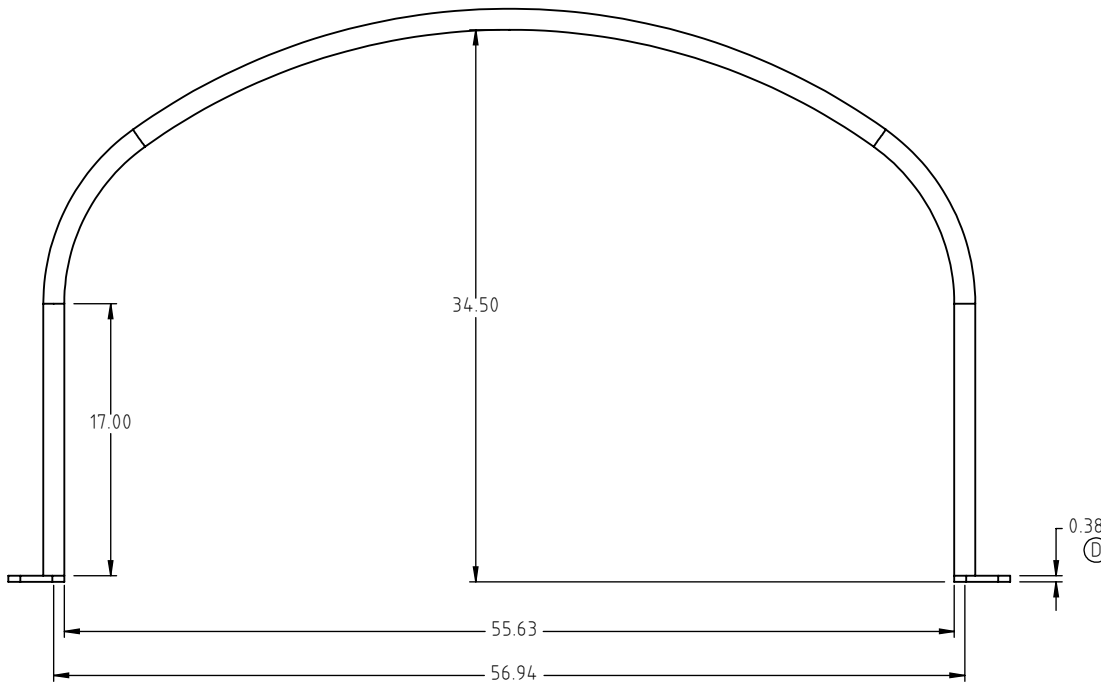
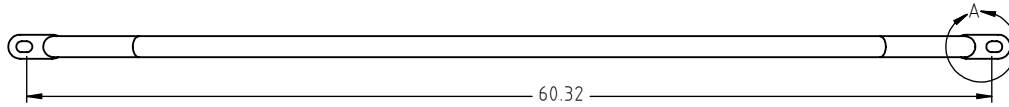
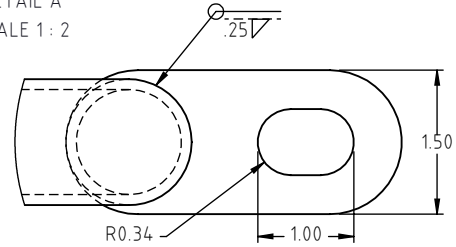

E	CHANGED MATERIAL, UPDATED SHEET FORMAT	SRA	2/7/2024	4559	DRAWN / DATE	MATERIAL:
D	T1315X01090-120 WAS 1.31 OD TUBE 12441 WAS SJF0735-HPP	ADH	6/12/2015	3081	NVE 8/17/2005	(D)(E) T1312X01090
C	FOOT UPDATED	ADH	8/27/2007		APPRD. / DATE	
REV.	DESCRIPTION	BY	DATE	CCN	REH 8/19/2005	
ALL DIMENSIONS ARE IN DECIMAL INCHES TOLERANCES UNLESS OTHERWISE SPECIFIED		THIRD ANGLE PROJECTION ANSI 14.5M		SHOT WEIGHT:		NOTES: BLANK LENGTH: 109.00"
POLYETHYLENE		METAL		SHIPPING WEIGHT: 12.00 LBS		
±1% @ 68°F		DECIMAL ± .125" FRACTION ± 1/4" ANGLE ± 1°		FINISH: Powder Coat		



**Den Hartog
INDUSTRIES, INC.**

Ace Roto-Mold • Injection Molding • Blow Molding • Sowjoy
4010 HOSPERS DRIVE S. BOX 425, HOSPERS, IOWA 51238-0425

DESCRIPTION HOOP FOR 510 GALLON FREE-STANDING TANK		
SCALE N.S.	PART NO. FS0510-HPS	SHEET 1 OF 1