

Copyright. All information furnished within this document, electronic file or design correspondence is the property of Den Hartog industries, Inc. and shall not be used, disclosed to others or copied without the expressed written consent of Den Hartog Industries, Inc.

FS1850-HPJ | 4 PER SET

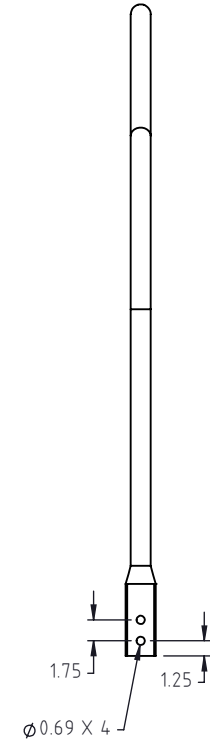

DRAWN / DATE SAS 10/10/2023	MATERIAL : MILD STEEL
APPRD. / DATE BES 10/30/2023	
SHOT WEIGHT:	NOTES: 1.) BLANK LENGTH 158"
SHIPPING WEIGHT: 32 LBS.	
FINISH: POWDER COAT	

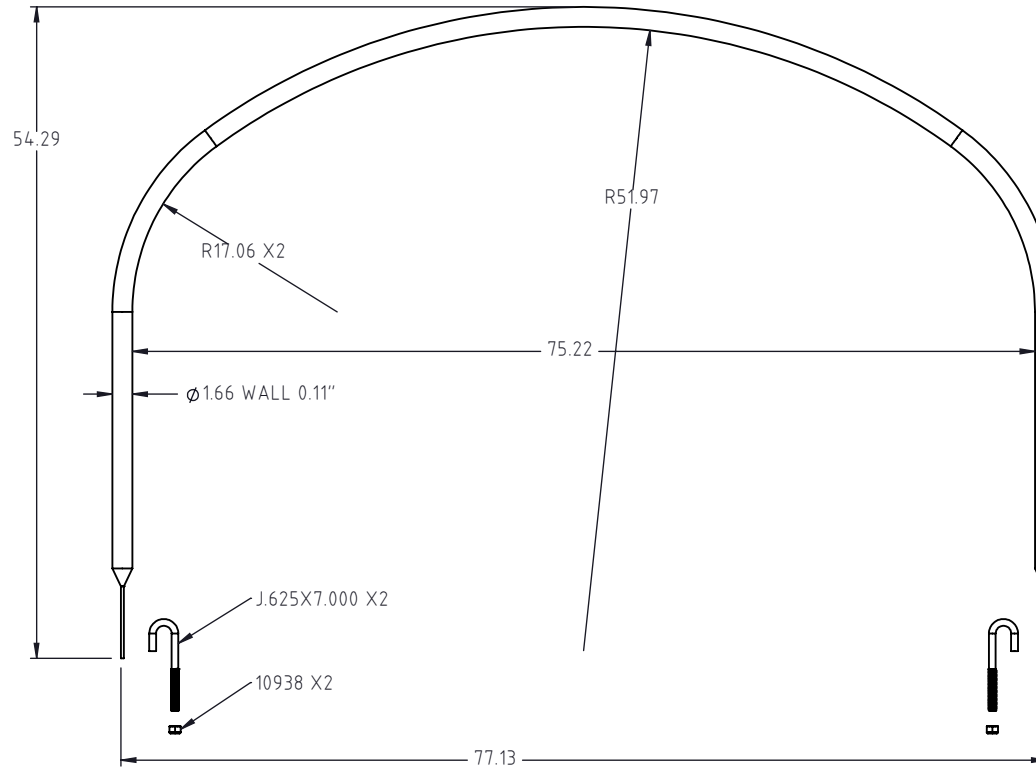

Den Hartog
INDUSTRIES, INC.

Ace Roto-Mold • Injection Molding • Blow Molding • Sowjoy
4010 HOSPERS DRIVE S. BOX 425, HOSPERS, IOWA 51238-0425

REV.	DESCRIPTION	BY	DATE	CCN
	ALL DIMENSIONS ARE IN DECIMAL INCHES TOLERANCES UNLESS OTHERWISE SPECIFIED			
	<u>POLYETHYLENE</u>			
	<u>METAL</u> DECIMAL ± .125" FRACTION ± 1/4" ANGLE ± 1°			

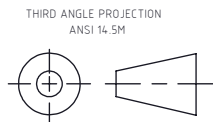

DESCRIPTION FS, HOOP 1850 GAL SINGLE W/J-BOLT		SHEET 1 OF 1
SCALE N.S.	PART NO. FS1850-HPJS	