

© DEN HARTOG INDUSTRIES, INC.

Copyright. All information furnished within this document, electronic file or design correspondence is the property of Den Hartog Industries, Inc. and shall not be used, disclosed to others or copied without the expressed written consent of Den Hartog Industries, Inc.

PART NUMBER	DESCRIPTION	MATERIAL	SHOT WEIGHT	SHIPPING WEIGHT
AFLS4896-24	AIR FLOAT, 48 X 96 X 24, LONG SLOT	10548	98 LBS.(44.5 KG.)	98 LBS.(44.5 KG.)
FFLS4896-24	FOAM FLOAT, 48 X 96 X 24, LONG SLOT			163 LBS.(73.9 KG)

LS4896-24

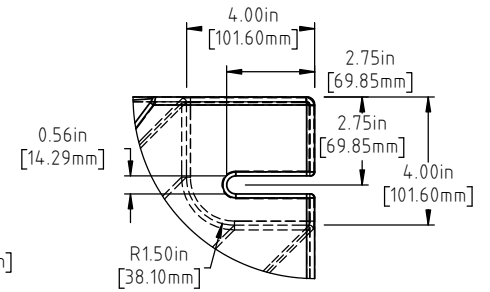
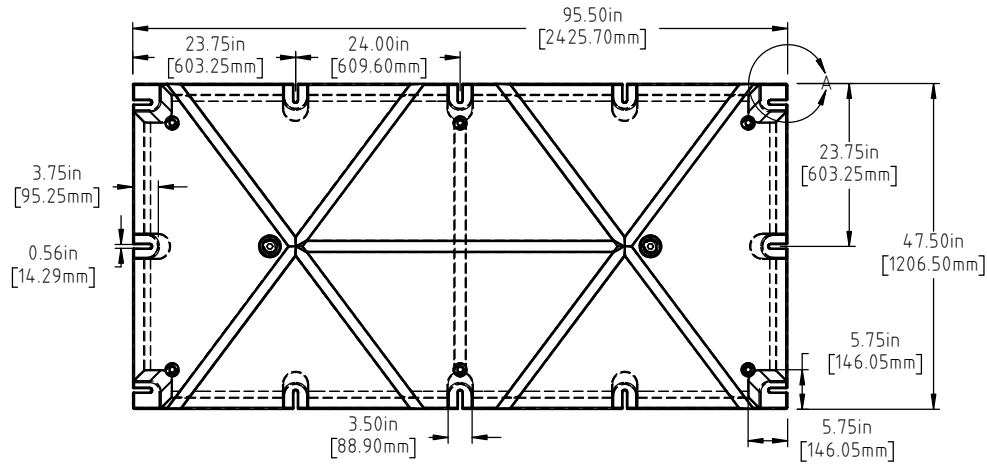

DETAIL A
SCALE 1:6

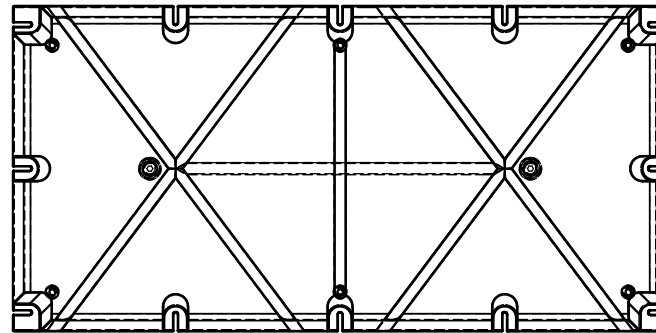
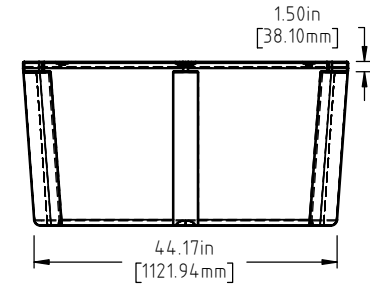
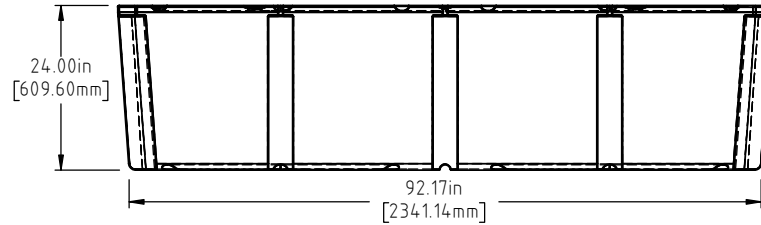
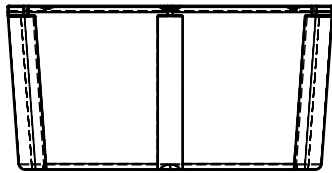

NOTE:BUOYANCY 3130 LBS.(1419.744 KG.)

REV.	DESCRIPTION	BY	DATE	CCN	DRAWN / DATE	MATERIAL
					ADH 1/21/2019	
ALL DIMENSIONS ARE IN DECIMAL INCHES TOLERANCES UNLESS OTHERWISE SPECIFIED					APPRD. / DATE	NOTES:
THIRD ANGLE PROJECTION ANSI 14.5M					REH 5/22/2019	
POLYETHYLENE		METAL			SHOT WEIGHT:	FINISH:
±1% @ 68°F		DECIMAL ± .125" FRACTION ± 1/4" ANGLE ± 1°			SEE TABLE	



Den Hartog
INDUSTRIES, INC.

Ace Roto-Mold • Injection Molding • Blow Molding • Sowjoy
4010 HOSPERS DRIVE S. BOX 425, HOSPERS, IOWA 51238-0425

DESCRIPTION	48 X 96 X 24 FLOAT-LONG SLOT		
SCALE	N.S.	PART NO.	LS4896-24
SHEET	1 OF 1		