

© DEN HARTOG INDUSTRIES, INC.

SJ10078

A

Copyright. All information furnished within this document, electronic file or design correspondence is the property of Den Hartog Industries, Inc. and shall not be used, disclosed to others or copied without the expressed written consent of Den Hartog Industries, Inc.

KEY	PART NUMBER	DESCRIPTION	QTY.
1	SJ10078-1	DOUBLE PLATE	1
2	SJ10078-2	DOUBLE-TAB	2
3	SJ10079-2	SINGLE TAB	2

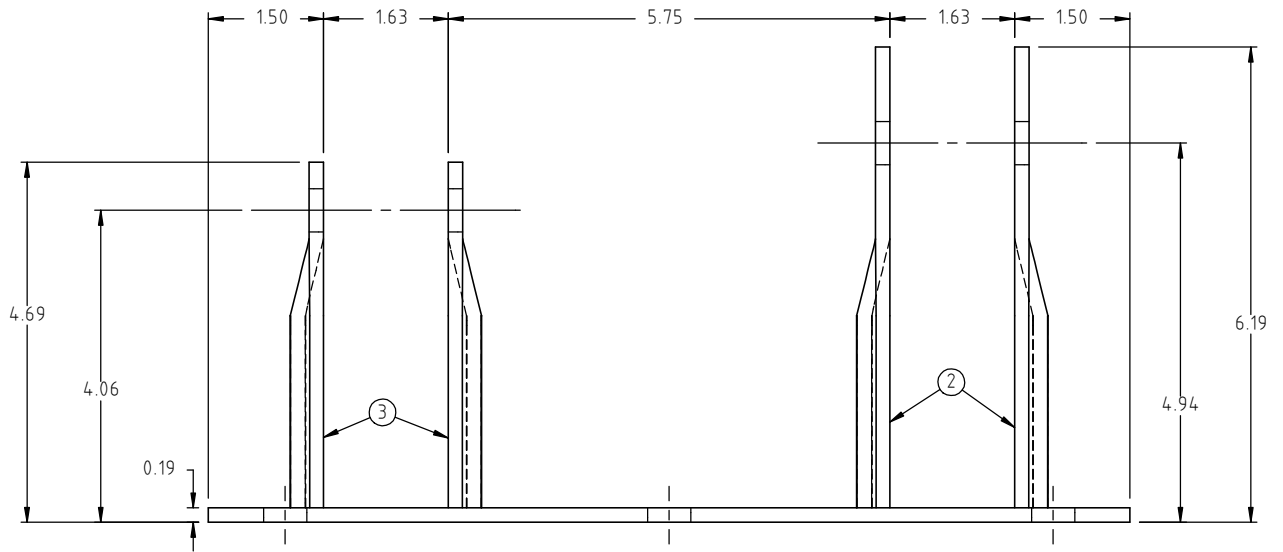
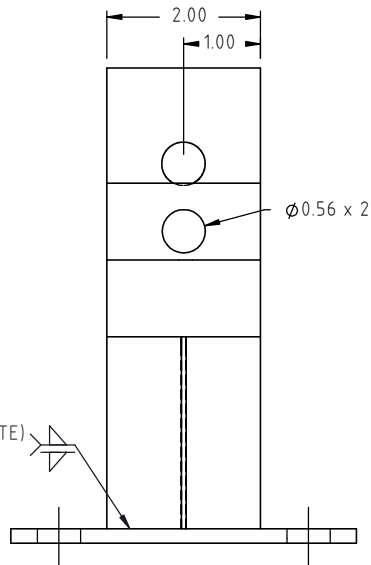
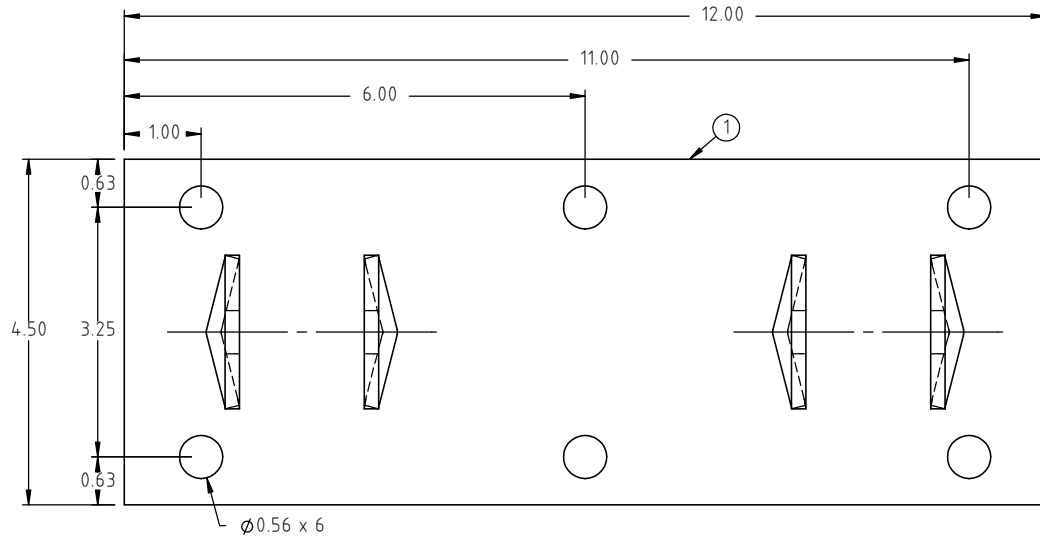

A	TABLE/WELD SYMBOL ADDED	ADH 4/10/13	2600
REV	DESCRIPTION	BY / DATE	CCN
ALL DIMENSIONS ARE IN DECIMAL INCHES TOLERANCES UNLESS OTHERWISE SPECIFIED		THIRD ANGLE PROJECTION ANSI 14.5M	
POLYETHYLENE	METAL DECIMAL ± .125" FRACTION ± 1/4" ANGLE ± 1°		
±1% @ 68°F			

DRAWN / DATE ADH 12/2/08	MATERIAL 1.) SHEET, 3/16" STAINLESS STEEL 2.) CUT FROM S-1875-SS
APPROD. / DATE KGJ 3/19/09	
SHOT WEIGHT:	NOTES:
SHIPPING WEIGHT: XXXX	
FINISH:	



# Den Hartog INDUSTRIES, INC.

Ace Roto-Mold Injection Molding Blow Molding Sowjoy

4010 HOSPERS DRIVE S. BOX 425, HOSPERS, IOWA 51238-0425

DESCRIPTION	PULLEY BRACKET, DOUBLE	
SCALE	N.S.	PART NO. SJ10078